

DESCRIPTION:

The **GEFCO Select #SE132-Series Rotators** are designed for professional built water displays, where continuous rotation of the spray head is expected and propulsion is not by spray jets. The spray heads are mounted on all stainless steel, self cleaning bearing chambers, as well as a #SE137-15 Adjustment Flange. The spray assemblies shall be installed perfectly vertical, showing only the top parts of the spray jets above water level. The spray heads are made of brass, bronze and copper. There are 2 drive jets, that can be adjusted to control the speed of rotation. The center jet is swivel mounted, peripheral jets can be flow and directional adjusted to suit the design. All single & center jets require non-twisting non-turbulent water supply! The use of 100 % filtered water is recommended.

The GEFCO Select #SE131 Series Rotating Jets can be installed on a GEFCO #PE109-Series Slab Penetration which will provide a rigid non-corrosive, waterproofing penetration.

TYPICAL SPECIFICATIONS:

- * **GEFCO Select #SE132 Rotating Jet:**
- made of cast bronze, brass and SST fitted.
- SST bearings
- w/ or w/out 0.375" center jet (specify) *
- 2, 4, 6 or 8 ea. 0.250" jets (specify)
- 1-1/2" N.P.T. female connection.

ADDITIONAL INFORMATION:

- Standard diameter is 12", other diameters available at an extra cost.
- **Suction Straining required to be: MAX. 0.125".**
- *: Single jet is off center 'Lariat' or 'Spiral' type spray effects.
- 'OH': 10.650"
- 'UT': 8.675" or 10.630" variable due to adjustments.

IMPORTANT NOTE:

The nozzle pressure should be designed never to exceed 19 feet of TDH.

PERFORMANCES: All jets at full height of 'SH'.

SE132-	SH	5Ft.	8Ft.	10Ft.	15Ft.
	FH	8Ft.	11Ft.	14Ft.	19Ft.
	N	GPM	GPM	GPM	GPM
-01	1	16	18	21	26
-02	2	17	20	22	26
-03	2+1	21	27	30	38
-04	4	25	29	33	39
-05	4+1	32	37	43	52
-06	6	33	39	47	55
-07	6+1	36	48	54	65
-08	8	41	49	55	67
-09	8+1	49	56	65	78

Rotators are designed to work in perfectly vertical alignment with given 'FH' pressure ratings.

IMPORTANT REQUIREMENT

Designers and Engineers shall be responsible for the accuracy of system flow rates and especially system head loss requirements. Stated flows and head pressure requirements for any listed spray height are required AT THE NOZZLE. Extrapolations for unlisted spray heights are at the sole responsibility of the Designers and/or Engineers.

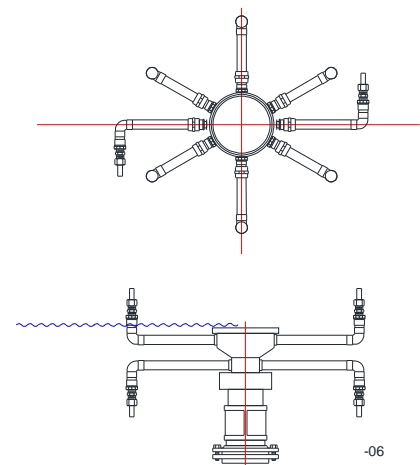
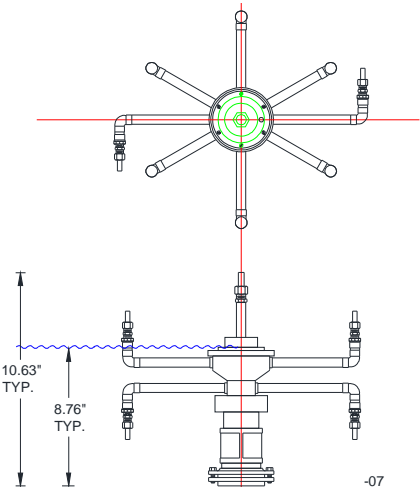
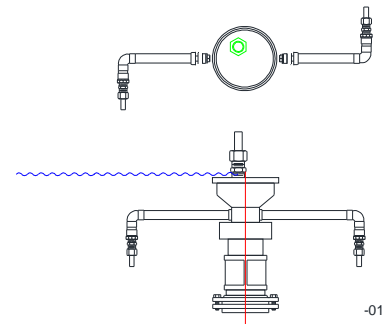

SCALE: NONE

IMPORTANT

Dimensions, Manufacturers and/or Materials subject to change without notice